



4L60 & E, 4L65-E, 4L70E

INPUT DRUM REINFORCEMENT SLEEVE KIT

H I G H P E R F O R M A N C E T R A N S M I S S I O N P A R T S

Part No.

77733-01K

Input Drum Reinforcement Sleeve, Seal & Piston Kit

Part No.

77733-01BLK

Input Drum Reinforcement Sleeve

Part No.

77733-02K

Input Drum Reinforcement Sleeve & Seal Kit

***Notes:** Will not repair a cracked drum. Late-model stamped forward pistons must be replaced with early-style cast-aluminum forward pistons.



Figure 1

INSTRUCTIONS

SLEEVE INSTALLATION:

1. Inspect the drum for cracks or damage. This sleeve will not repair a cracked drum. Set the input drum into a hydraulic press (or arbor press). Use an appropriate sized tube or a spare (not to be reused) 4L60 stator shaft with the selective spacer (with bearing left out) to support the aluminum housing directly under the area being pressed on. A 4L60-E rear sun gear works well to drive the sleeve on.

CAUTION: Not supporting the drum directly under the sleeve can result in damage to the shell.

- 2. Refer to Figure 1. Clean the reinforcement sleeve area and take note of the overrun clutch feed hole location.
- 3. Thoroughly clean the reinforcement sleeve.
- 4. Coat the inside of the sleeve with green Loctite™ 609. With the tabs located toward the inside of the drum, line up the overrun clutch oil feed hole between the sleeve tabs. Then set the sleeve into position on the input drum.
- 5. Using the press, install the sleeve until just barely seated. Do not seat the sleeve with the full force of the press since excessive force will ruin the housing. Do NOT hammer or pound the sleeve into place.

4L60 & E, 4L65-E, 4L70E Input Drum Reinforcement Sleeve Kit

PISTON MODIFICATION:

NOTE: If you have 77733-01K, move on to INPUT DRUM ASSEMBLY as it includes a modified overrun piston.

1. The kit requires an early-style cast aluminum OEM overrun piston in good working order. **NOTE:** Late model steel overrun pistons with bonded lip seals cannot be used.
2. Fixture the overrun piston in a lathe and indicate the ID so it is running true.
3. Bore the ID out $\text{\O}1.834"/1.829"$. Radius both sides of the seal groove with $R.005"/.015"$ radii. Make sure to deburr both outer edges (see Figure 2).
4. Thoroughly clean the piston of any chips, debris or cutting fluid.

INPUT DRUM ASSEMBLY:

1. Use the modified early-style cast-aluminum OEM overrun piston with an early-style cast-aluminum forward piston. The late-model stamped steel forward piston cannot be used (see Figure 3). If you are rebuilding a late-model unit that has a stamped steel forward piston you must obtain an early-style cast-aluminum forward piston.

NOTE: A recommended measure before installation is to seat the checkball in the overrun piston with a small punch.

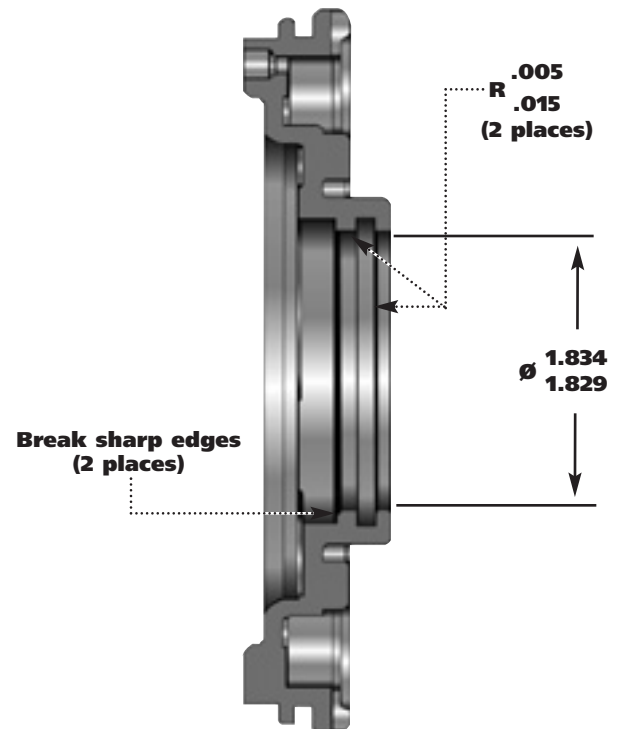

Figure 2

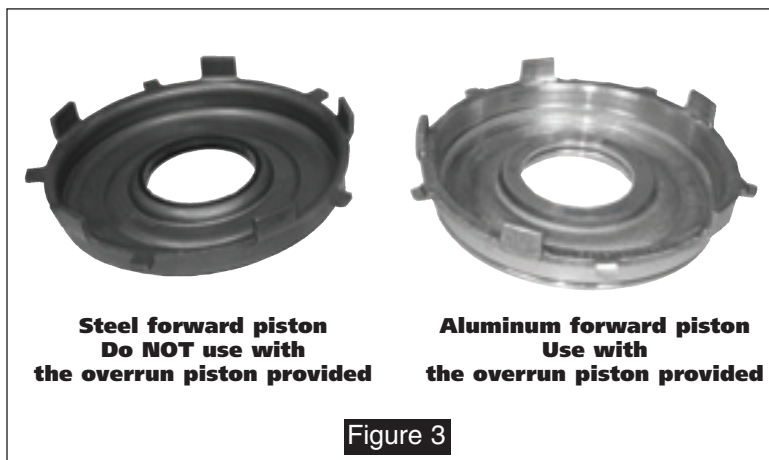

Figure 3

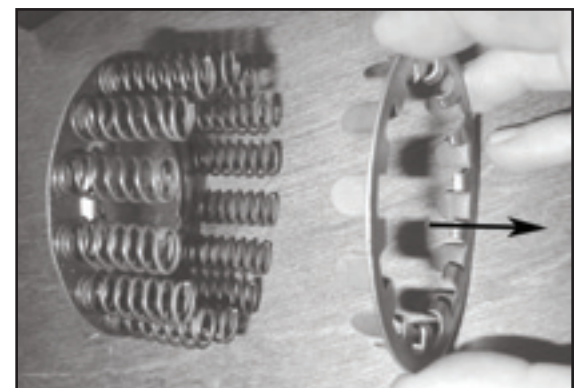

Figure 4

2. If using a late-model return spring assembly (identified by 2 spring retainers on both ends of the springs) remove and discard the lower spring retainer (see Figure 4). Although not required, the early-style return spring used with OEM aluminum pistons is about 10% stronger and is preferred for high rpm applications.
3. Assemble input drum as usual.